

YCOE Board Update

February 28, 2017

Early Childhood Education Program Highlights

- **ECE Literacy program**, with support from KVIE, was able to provide 4 workshops for our families. The workshop titles were: TV As A Learning Tool, Math Is Everywhere, and Healthy Habits. These workshops were offered in various sites in West Sacramento and Woodland. One hundred families attended the training. The trainings were delivered in English and Spanish, child care was provided and each family receive a book for attending.
- **Families participated in Cardboard Creations.** The children were investigating the topic of Reduce, Reuse and Recycle. The culminating family event was for the children to build a robot at home with their family and bring it into school to share.
- **Collaboration project with *Explorit*, YCOE and ECE program** continues in full force. The children have been offered exciting activities around the topic of Ramps. They have been learning new vocabulary words such as; slope, elevation, speed, hypothesis, force, design, cause and effect.

Special Education

- **Student Transition Symposium** held at YCOE on February 27 - approximately 100 students that receive special education services in Yolo participated including: YCOE students from Davis Senior High Horizon, Woodland High School Horizon, and the two ALS classes participated in sessions on supported living, getting a job, colleges, and so much more.
- **Arts/Music:** Our YCOE special education Classes have a variety of activities that they are participating in such as:
 - Greengate had the *Blues in the School* in February
 - Greengate; Whitehead Horizon elementary classes; and the ALS classes have been participating in a Music Therapist leading the classes in musical exploration/lessons/etc.
- **Upcoming events** Saturday, March 18th will be the NorCal Trykers bike build day; Saturday, March 25th will be the Bike give away at Greengate for our ten students/families that have bikes being donated to them
 - Yolo Arts is scheduled to provide lessons in all of our classes with topics such as ceramics; 2 dimensional art; and a variety of other art activities to our classes

Curriculum, Instruction & Student Services

- **Students at Chavez – West Sacramento** have been participating in an “Energy & Electronics Academy” – weekly hands-on career exploration/experience sessions facilitated by Krista Purdom, Educational Technology Specialist; Andy Codd, College & Career Specialist and Deb Bruns, STEM Coordinator. Students have learned about careers in computer programming, electronics, telecommunications installation, and solar energy while completing projects that

include wiring sockets & switches, installing cable, making music by programming and wiring a cardboard guitar, and assembling a solar PV system to produce and store energy

- **Industry tours** in areas of hospitality, manufacturing, and agricultural industry sectors.
- **Youth in Transition event** at Yolo COE on 2/6. The workshop provided information about serving and advocating for foster youth and homeless youth. Over 80 people attended representing social services, school counselors, attendance liaisons, postsecondary institutions, and community based organizations.
- **Hosted industry roundtables** in the community focusing on skills gaps and developing short term career technical education programs to meet employer needs.
- Partnership with Sutter COE the **Drone Commercial Licensing short term CTE program**. The 10-week course is open to adults and will prepare them for the state certification required to operate drones for commercial use. The course is offered via distance education. (flyer attached)
- **Upcoming event:** Celebration of Ethnic Studies, March 4th from 8:00 - 3:00 at Pioneer High School.
- **Upcoming event: Second Project SOLAR field trip to Grasslands Regional Park.** On March 21, 28 Davis HS students will make a second visit to Grasslands Regional Park to complete a native plant restoration project and learn about the park's unique habitats and ecosystems, including the vernal pools. The students are learning about the park (including the Yolo County solar farm there) in order to teach their peers as part of an alternative energy unit in the Chemistry & the Community classes. (In January the students planted over 100 native plants, toured the solar farm and participated in a learning activity to make connections between solar energy and the many uses of the park.)
- **Presentation to the Blue Ribbon Commission** regarding Building a Resilient Yolo on Foster Youth
- **2nd Annual African American Student Leadership Conference:** 136 youth in attendance, with close to 200 participants, including parents and grandparents (KCRA 3 covered the event)
- **"Creating Safe Spaces"** (Be the Change Through Unity event) event 30 participants
- **Second Chance Through Music grant** implementation initiated at Dan Jacobs
- **Green Beret, Trino Savala, Jr.,** guest speaker at Dan Jacobs

Yolo County SELPA

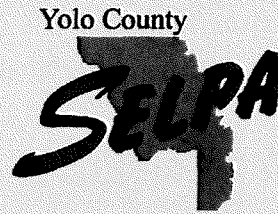

Family Transition Symposium

March 21, 2017, 6 - 8 PM

Woodland High School Library

6:00 – 8:00 PM – **Vendor Fair**

NorCal Services for the Deaf; Fly Brave; MIND Institute; Team Davis (Best Buddies); Yolobus; Yolo Employment Services (YES); Supported Life; California Department of Treasury (Cal ABLE Accounts); WJUSD Adult Living Skills Program; Alta California Regional Center; College to Career at Sacramento Community College; Disability Rights of California; Warmline Family Resource Center; Yolo SELPA Community Advisory Committee (CAC); Sonin Law (Conservatorships); State Council on Developmental Disabilities; Stepping Out; Department of Rehabilitation; UC Davis Early Academic Outreach Program (EAOP)

6:30 – 7:10 PM **Session 1 – Room 1001**

Group 1 – Carrie Fisherstone (Cal ABLE Program)

Group 2 – Candito Servera & Jose Garcia (Department of Rehab)

7:15 – 8:00 PM **Session 2 – Room 1002**

Group 1 – Barbara Sonin (Conservatorships)

Group 2 – Monica Villegas (UC Davis EAOP – College Readiness)

Corazon – Applying Science Technology Engineering Arts & Math to the Real World

Developing a Passion through an Engaging Hands-On & Learn-By-Doing Approach!

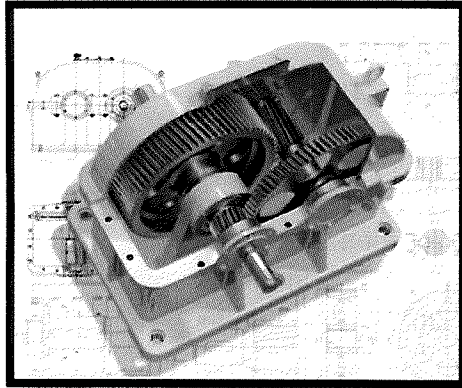

Corazon Environment

- Driven by industry needs and entrepreneurial focused
- Safe and clean center to include: industrial Makerspace, fabrication studio, composites lab, assembly and production, manufacture and product development technology
- Display Gallery and community art center

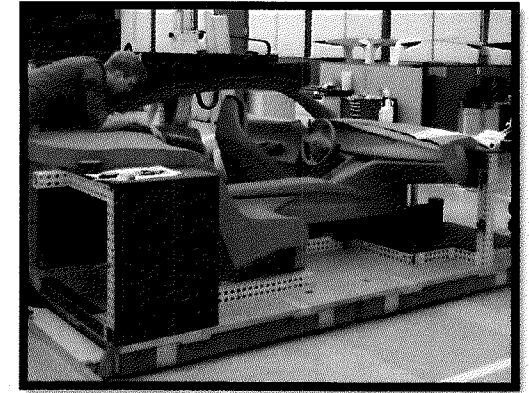

Hard Skills

Industry Aligned – by Industry

- Product Design
- Manufacturing
- CNC Machining, CAD, & CAM
- Fabrication
- Composite Technology
- Engineering
- Sales & Marketing
- Equipment Maintenance

Soft Skills

Employer driven focus:

- Professionalism/Integrity
- Communication
- Reliability
- Problem Solving
- Creativity/Innovation
- Teamwork
- Self-Direction

Support Services

External and internal structures:

- Work Based Learning Resources
- Internships/On the Job Training
- Cross Age Mentoring
- Transition Services
- Collaboration with Postsecondary
- Partnerships with Employers
- Career Exploration and Goal Planning

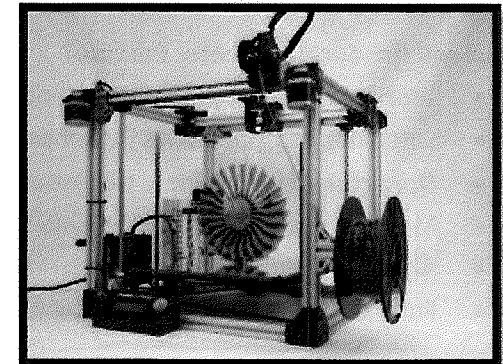

Corazon – Applying Science Technology Engineering Arts & Math to the Real World

Developing a Passion through an Engaging Hands-On & Learn-By-Doing Approach!

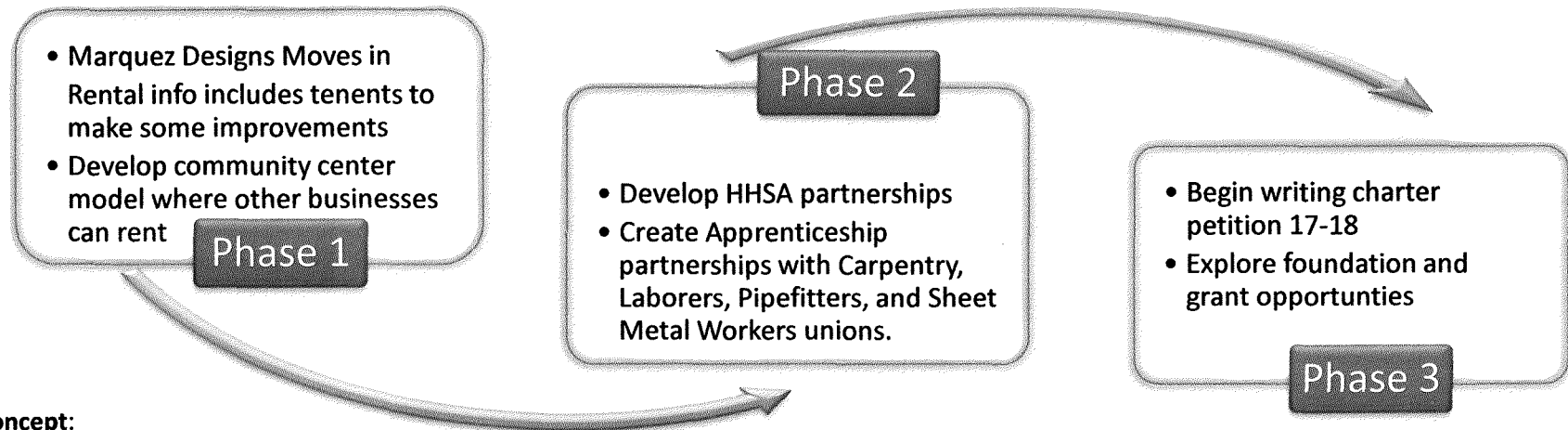

Proposed Concept:

- Utilize the 16,000+ square foot vacant area to develop a community STEAM Center
 - The center will start out small with a business-industry focus and will not utilize the entire space
 - The center will rent out space to businesses who have a passion with working with youth and in turn provide community classroom support
 - The center will collaborate with local community based organizations focused in STEAM and workforce development
 - The center will provide a gallery of student work to be on display and purchased by the public

What is needed in the space:

- Roll up Door (preferably a window based roll up door to coincide with the STEAM environment)
- All STEAM related activities will be conducted in a safe indoor environment
- A Makerspace lab will be created
- All equipment and machinery will be industry aligned
- The space will feature industry focused labs (CNC machining, CAD, Etc...)

What will the Corazon Center Provide?

- Workforce Development and Hands-On STEAM Exploration – Sustainable Funding through Adult Short Term CTE Training
- Soft Skills and Hard Skills Development with Support Services
- Opportunity for business and industry to collaborate and provide in-kind or financial support through donation of time or equipment
- Meet a skills gap need in the Yolo County Community in areas of STEAM and specifically Manufacturing Industry Sector
- Allow for learning through experimenting, creating, and innovation
- Future Space for Charter serving 16-24 year old students.

Drone/UAV Commercial Certification Course

Operate small drones commercially



- Prepare to pass the Federal Aviation Administration (FAA) Part 107 license exam
- Conduct safe flight operations
- Identify National Air Space (NAS)
- Find and successfully interpret Temporary Flight Restrictions (TFR)
- Must be at least 18 years old

**Class starts 3/7/17
5:00-7:00 PM
Tuesday & Thursday
Class Ends: 5/11/17**

**To register, please contact:
Yolo County Office of Ed
Eric Banelos
530-668-3717
Eric.Banelos@ycoe.org**

**C.O.R.E.
Aerospace STEM**

**Classes will be held at Woodland Community College:
2300 E. Gibson Road, Woodland 95776 – 600 Building
Students will participate via video conference and engage in hands-on activities**



Equal Opportunity Employer/Program

Auxiliary aides & services are available upon request to individuals with disabilities.



The Sutter County One Stop is a proud partner of America's Job Center of CaliforniaSM network.



QUESTIONS RESPONSES 26

26 responses



SUMMARY **INDIVIDUAL**

Accepting responses



Are you a participant of the PLN? (26 responses)

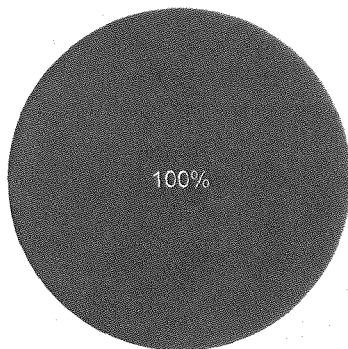

- Yes
- No

Which county are you from? (26 responses)

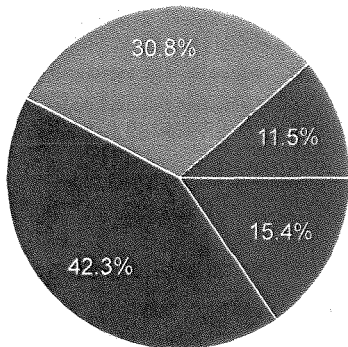

- Colusa County
- Sutter County
- Yolo County
- Yuba County

Have you populated the new SBE – approved LCAP Template and Annual update with last year’s approved LCAP information?

(26 responses)

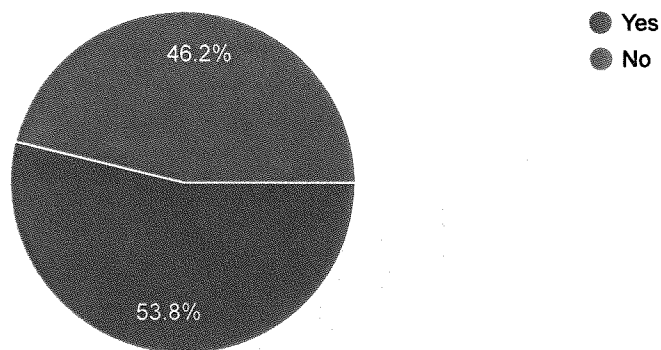

Have you been collecting data for analyzing your progress on local and state performance Indicators?

(26 responses)

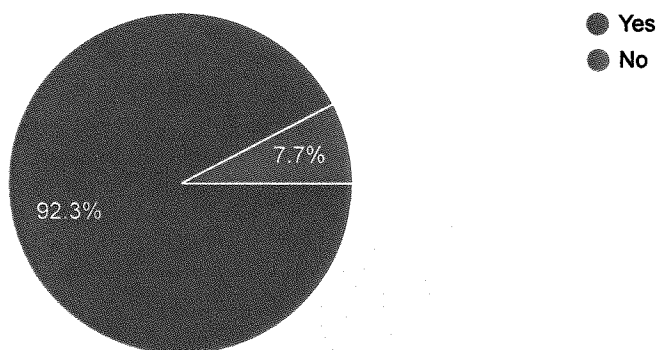

Have you been tracking expenditures on actions and services for 2016-2017?

(26 responses)



- Yes
- No

I can name the 7 State Performance Indicators (26 responses)

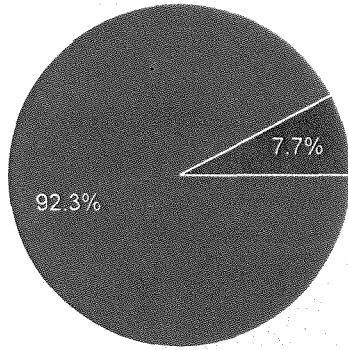

- Yes
- No

I can name the 4 Local Performance Indicators (26 responses)

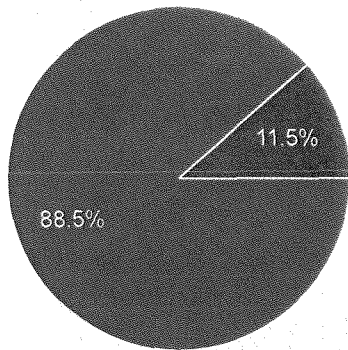

- Yes
- No

Rate your knowledge below



I am familiar with the layout and content of the evaluation rubrics. (26 responses)

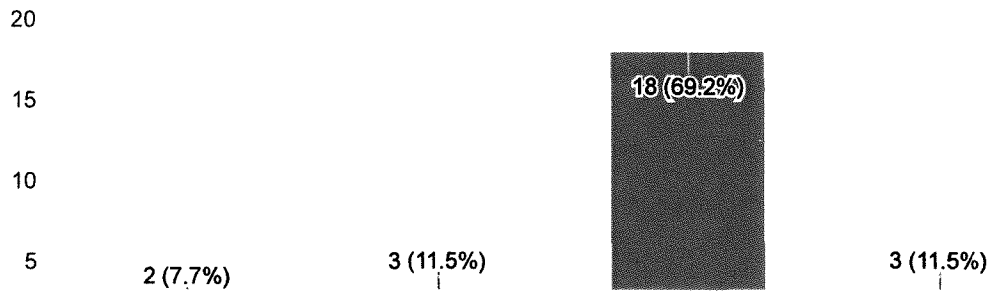

I know how the indicators receive a performance category. (26 responses)

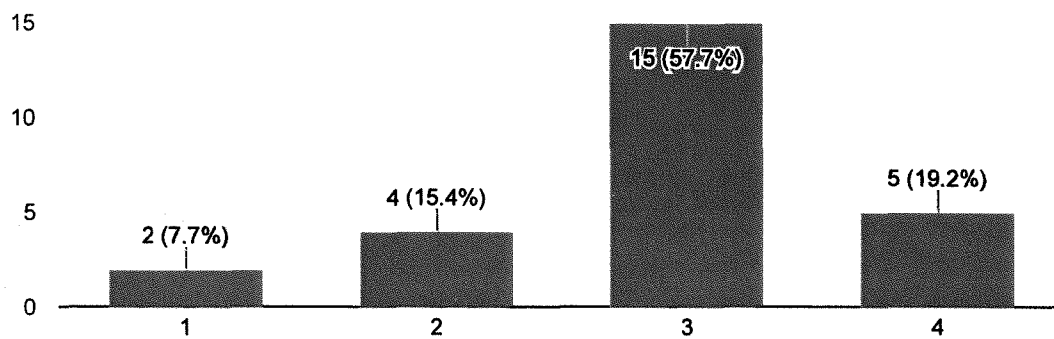

I am able to distinguish between status and change on the reference chart. (26 responses)

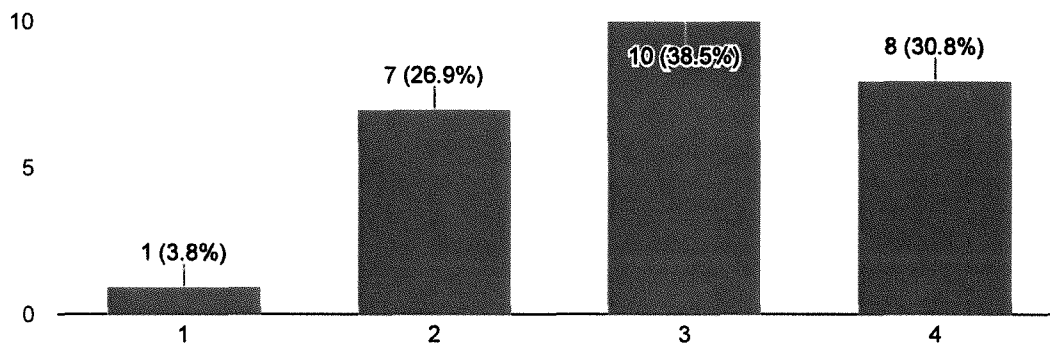

I am able to distinguish between state and local indicators. (26 responses)

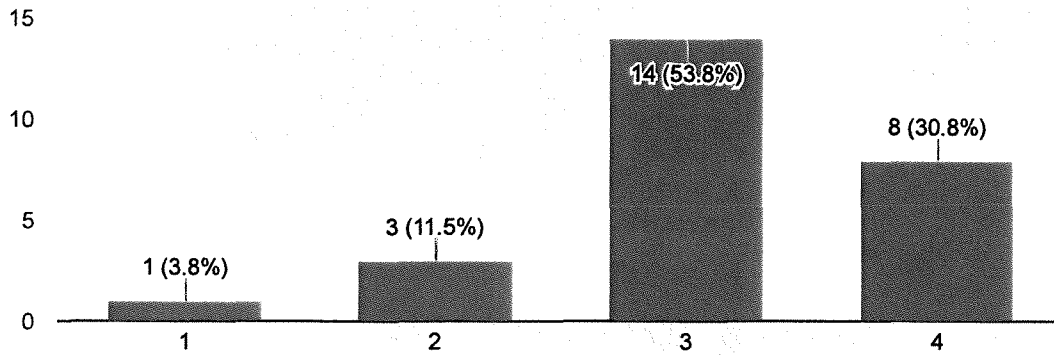

I know how to share Equity Data Reports with stakeholders. (26 responses)

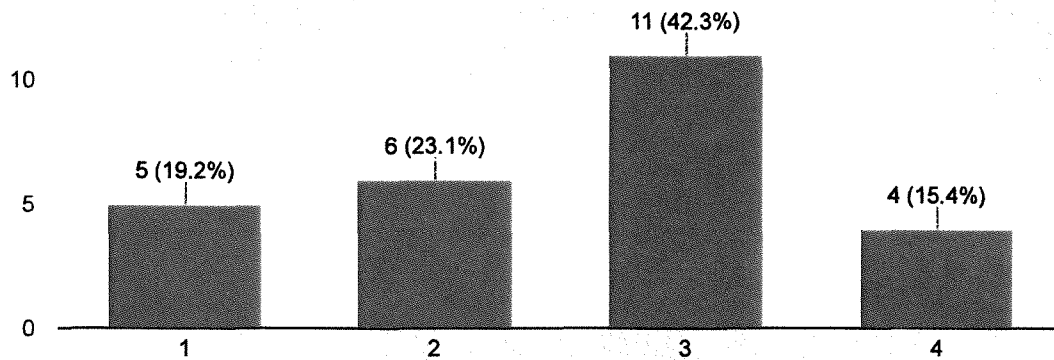

I am able to identify patterns among indications and student groups (26 responses)

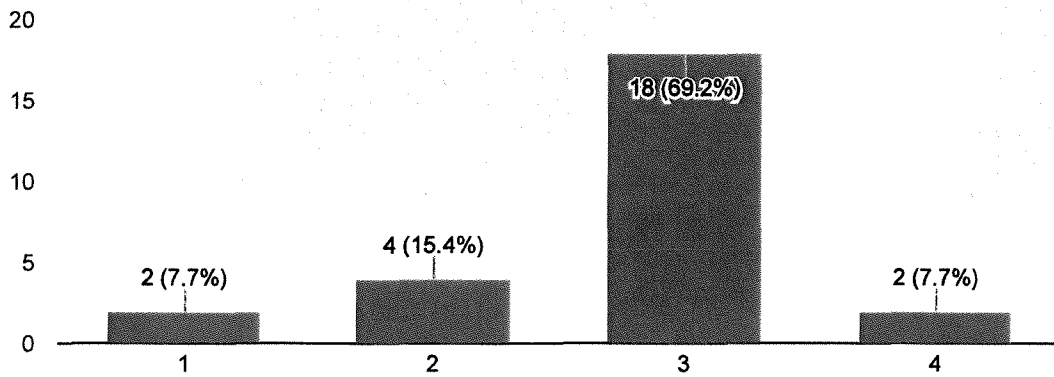

I understand the purpose of statements of model practice and external links

I understand the purpose of statements of model practice and external links
(26 responses)

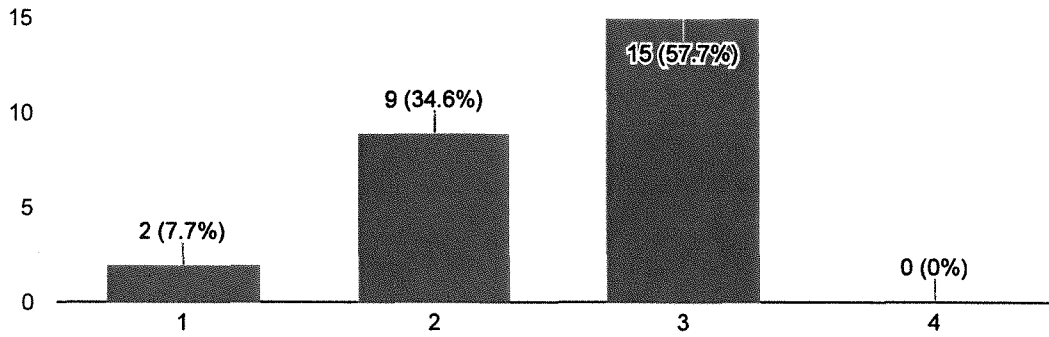

I can begin process of examining potential causes of performance for an indicator

(26 responses)

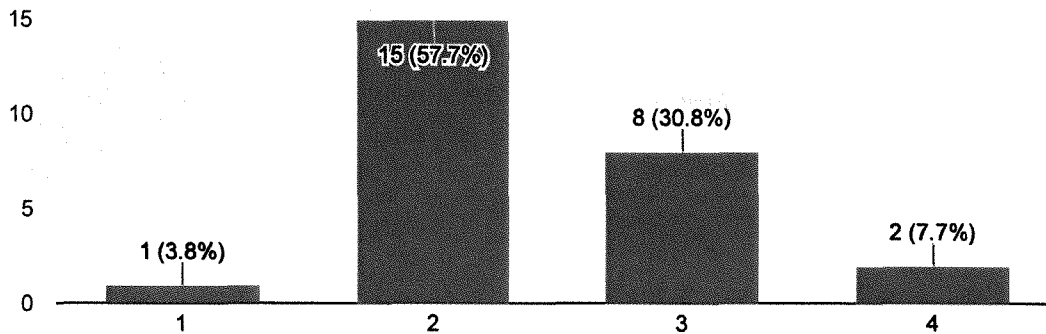

Short Answer

1. What questions do you have regarding using the new template and evaluation rubrics for demonstrating your districts process for continuous improvement?

(26 responses)

None

None

nnnn

I desire continued training

What is the anticipated timing of the state's populating the evaluation rubrics with data for the LCAP?

How should we maximize time to meet all these new requirements and tools?

stakeholder engagement continues to be a challenge – need to attract more individuals and groups to the table

na

Due to its size and rural nature, our school district has no English Learners currently enrolled. Will we need to show a process for improvement in areas that do not reflect our current school population?

are there any sample annual updates with exemplar evaluations

What supports are available to help us in this process?

None at this time

2. What questions do you have regarding using the new template and evaluation rubrics for demonstrating your districts process for continuous improvement?

(26 responses)

None

None

None at this time.

None at this time.

nnnn

With the template change each year we tend to focus on that vs improvement. Will this template remain for a few years?

Advice about developing strong local indicators.

How should I use the evaluation rubrics, since we do not have a score yet?

see above - repeated question

na

With a district enrollment that fluctuates between 50 and 70 students, will confidentiality be an issue in reporting or using the evaluation rubric for demonstrating our districts processes through data?

3. What topic regarding LCAP implementation and the continuous improvement process would have the greatest value to your LCAP Team?

(26 responses)

nnnnn

How to analyze the data and build a new plan when much of the data is received after the plan is developed

Advice about the steps we need to follow if we decide to change an existing goal, with particular attention to ensuring that our LCAP will pass YCOE review.

What is an appropriate timeline calendar and what tools are available to do the work? How can we access these tools? Are there videos that can help us with the different pieces we need to build knowledge base in, so we can access the topics we need one-on-one help with?

I'd like to know how other districts are engaging in program evaluation, whether they are doing evaluation in house or contracting out. And how much detail are they getting into, in the evaluation?

na

Determining and connecting LCFF expenditures to annual LCAP goals, services, and actions.

Model practices for each performance indicator

Guidance on local measures.

None at this time

Comments or anything else you would like to share (9 responses)

nnnnn

My county has done little to nothing to train us - I feel like we are at step one in the process

I do not want to be told or walked through something that does not apply to the LCAP work I need to do for my particular district. I don't have time to do extra stuff!

I am feeling overwhelmed and need time to digest the information and process it with y team

Our meetings are worthwhile.

Training to date has been very helpful.

The Sutter County Office of Ed is very thorough with assisting with LCAP

I love Dorothy's Team. I think we need t-shirts that say, "TEAM DOROTHY!"

The County Office has been very helpful and supportive